

RCA

nvvistor

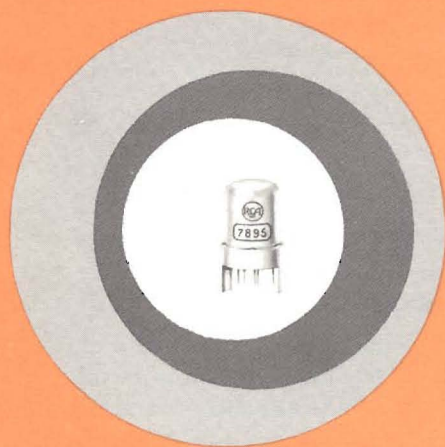

7895

HIGH-MU TRIODE

($\mu = 64$)

for INDUSTRIAL APPLICATIONS

■ High transconductance at low plate current ■ High gain with low noise ■ Low heater drain ■ High resistance to shock and vibration ■ Exceptional uniformity of characteristics from tube to tube ■ Operation at full ratings at all altitudes ■ Rigorously controlled and tested ■ All-metal and ceramic construction ■ Only $\frac{9}{16}$ inch long; less than $\frac{1}{2}$ inch in diameter; weighs $\frac{1}{15}$ oz.



RADIO CORPORATION OF AMERICA
Electron Tube Division
Harrison, N. J.

RCA-7895

HIGH-MU TRIODE

Nuvistor Type for Industrial Applications

Amplification Factor = 64

RCA-7895 is a high-mu nuvistor triode of the heater-cathode type designed for use in a wide variety of applications in industrial equipment where compactness, low drain, negligible interface resistance, exceptional uniformity of characteristics from tube to tube, and ability to withstand severe mechanical shock and vibration are primary design requirements. It is capable of providing high gain with low noise in amplifier service, excellent stability as an oscillator over a wide range of frequencies, and reliable performance in applications such as on-off control involving long periods of standby operation.



*Actual
Size*

The 7895 is rigidly controlled during manufacture, and is subjected to rigorous tests for intermittent shorts and interelectrode leakage; for early-hour, 100-hour, and 1000-hour conduction life performance; for 1000-hour standby life performance; for resistance to impact shock, low-frequency vibration, variable-frequency vibration, low-pressure breakdown, and heater cycling.

These special controls and tests, together with high transconductance at low-plate current and voltage, small power requirements, ability to operate at full ratings at any altitude, and extremely small size, make the 7895 nuvistor high-mu triode exceptionally desirable for critical industrial applications.

General Features

The 7895 has a metal envelope provided with two peripheral lugs of unequal width for indexing, is only 8/10" long, less than 1/2" in diameter, and weighs approximately 1/15 ounce (1.9 grams). It features (1) a very rugged structure of unique design, (2) a 6.3 volt low-wattage heater, and a specially designed cathode made of passive material to assure very low interface resistance and leakage, (3) high transconductance at low plate voltage and current (9400 micromhos at 110 volts and 7.0 milliamperes), (4) very high input impedance, (5) high perveance, and (6) ability to operate at full ratings at any altitude.

Structural Features

A major feature of the 7895 is its all-ceramic-and-metal construction utilizing a light-weight, cantilever-supported cylindrical electrode structure. This unique type of electrode structure, inherent in the nuvistor design, uses

Structural Features (Cont'd)

only strong metals and ceramics to provide a structure of extreme ruggedness. All connections are brazed at very high temperatures in a hydrogen atmosphere to eliminate the structural strain and element distortion often caused by welding. The tube is also exhausted and sealed at very high temperatures to eliminate the gases and impurities which are generally present in electron devices processed at low temperatures.

The structure of the 7895 nuvistor triode also permits automatic assembly using parts made to extremely small tolerances, thus assuring exceptional uniformity of characteristics from tube to tube.

GENERAL DATA

Electrical:

Heater, for Unipotential Cathode:

Voltage (ac or dc)	6.3 ± 10%	volts
Current at 6.3 volts	0.135	amp

Direct Interelectrode Capacitances (Approx.):

Grid to plate	0.9	μf
Grid to cathode, heater, and shell	4.2	μf
Plate to cathode, heater, and shell	1.7	μf
Heater to cathode	1.3	μf
Plate to cathode	0.22	μf

Characteristics, Class A₁ Amplifier:

Plate-Supply Voltage	110	volts
Grid-Supply Voltage	0	volts
Cathode Resistor	150	ohms
Amplification Factor	64	
Plate Resistance (Approx.)	6800	ohms
Transconductance	9400	μmhos
Plate Current	7.0	ma
Grid Voltage (Approx.) for plate current = 10 μa	-4	volts

Mechanical:

Operating Position	Any
Maximum Over-all Length	0.8"
Maximum Seated Length	0.625"
Maximum Diameter	0.440"
Envelope	Metal Shell
Base	Medium Ceramic-Wafer Twelvar 5-Pin (JEDEC No. E5-65)
Socket	Cinch Mfg. Co. No. 133 65 10 001, or Equivalent

INDUSTRIAL SERVICE

Maximum Ratings, Absolute-Maximum Values:

For Operation at Any Altitude

PLATE SUPPLY VOLTAGE	330 max.	volts
PLATE VOLTAGE	110 max.	volts
GRID VOLTAGE:		
Negative-bias value	55 max.	volts
Peak positive value	2 max.	volts

PLATE DISSIPATION	1 max.	watt
GRID CURRENT	2 max.	ma
CATHODE CURRENT	15 max.	ma
PEAK HEATER-CATHODE VOLTAGE:		
Heater negative with respect to cathode	100 max.	volts
Heater positive with respect to cathode	100 max.	volts

Maximum Circuit Values:

Grid-Circuit Resistance: *

For fixed-bias operation	0.5 max.	megohm
For cathode-bias operation	1 max.	megohm

* For Operation at Metal-Shell Temperatures up to 150° C (See Dimensional Outline Drawing on Page 9).

CHARACTERISTICS RANGE VALUES FOR EQUIPMENT DESIGN

	Note	Min.	Max.	
Heater Current	1	0.125	0.145	amp
Direct Interelectrode Capacitances:				
Grid to plate	2	0.8	1.0	μμf
Grid to cathode, heater, and shell	2	3.4	5.0	μμf
Plate to cathode, heater, and shell	2	1.3	2.1	μμf
Heater to cathode	2	1.0	1.6	μμf
Plate to cathode	2	.16	.28	μμf
Plate Current (1)	1,3	5.5	8.8	ma
Plate Current (2)	1,4	-	50	μα
Transconductance (1)	1,3	7900	10900	μmhos
Transconductance (2)	3,5	6900	-	μmhos
Transconductance Change:				
Difference between Transconductance (1) and Transconductance (2), expressed in per cent of Transconductance (1)				
	-	-	15	%
Reverse Grid Current	1,6	-	0.1	μα
Amplification Factor	1,3	54	74	
Heater-Cathode Leakage Current:				
Heater negative with respect to cathode	1,7	-	5	μα
Heater positive with respect to cathode	1,7	-	5	μα
Leakage Resistance:				
Between grid and all other electrodes tied together				
	1,8	1000		megohms
Between plate and all other electrodes tied together				
	1,9	1000		megohms

Note 1: With 6.3 volts ac or dc on heater.

Note 2: Measured in accordance with EIA Standard RS-191-A.

Note 3: With dc plate volts = 110, cathode resistor = 150 ohms, and cathode-bypass capacitor = 1000 μf.

Note 4: With dc plate volts = 110, dc grid volts = -5, and metal shell grounded.

Note 5: With 5.7 volts ac or dc on heater.

Note 6: With dc plate volts = 150, grid-supply volts = -1.7, grid resistor = 0.5 megohm, and metal shell grounded.

Note 7: With 100 volts dc applied between heater and cathode.

Note 8: With grid 100 volts negative with respect to all other electrodes tied together.

Note 9: With plate 300 volts negative with respect to all other electrodes tied together.

SPECIAL RATINGS AND PERFORMANCE DATA

Shock Rating:

Impact Acceleration 1000 max. g

This test is performed on a sample lot of tubes from each production run to determine ability of tube to withstand the specified impact acceleration. Tubes are held rigid in four different positions in a Navy Type, High-impact (flyweight) Shock Machine and are subjected to 20 blows at the specified maximum impact acceleration. At the end of this test, tubes are criticized for change in transconductance, reverse grid current, and heater-cathode leakage current, and are then subjected to the Variable-Frequency Vibration Test described later.

Fatigue Rating:

Vibrational Acceleration. 2.5 max. g

This test is performed on a sample lot of tubes to determine ability of tube to withstand the specified vibrational acceleration. Tubes are rigidly mounted, supplied with normal heater voltage only, and subjected for 48 hours to 2.5 g vibrational acceleration at 60 cycles per second in a direction perpendicular to the longitudinal axis of the tube. At the end of this test, tubes are criticized for the same characteristics and end-point values as in the Shock Rating Test described previously.

Variable-Frequency-Vibration Performance:

This test is performed on a sample lot of tubes from each production run. The tube is operated under the conditions specified in CHARACTERISTICS RANGE VALUES for Transconductance (1) with the addition of a plate-load resistor of 2000 ohms. During operation, tube is vibrated in a direction perpendicular to the longitudinal axis of the tube through the frequency range from 50 to 15000 cycles per second under the following conditions: a sweep rate of one octave per 30 seconds from 50 to 3000 cps, a 7-second sweep from 3000 to 15000 cps, and a constant vibrational acceleration of 1g. During the test, tube must not show an rms output voltage in excess of:

35 mv over the frequency range from	50 to	3000 cps
60 mv over the frequency range from	3000 to	6000 cps
500 mv over the frequency range from	6000 to	15000 cps

Low-Pressure Voltage-Breakdown Test:

This test is performed on a sample lot of tubes from each production run. In this test tubes are operated with 240 rms volts applied between plate and all other electrodes and will not break down or show evidence of corona when subjected to air pressures equivalent to altitudes of up to 100000 feet.

Heater Cycling:

Cycles of Intermittent Operation. 2000 min. cycles

This test is performed on a sample lot of tubes from each production run under the following conditions: heater volts = 7.5 cycled one minute on and two minutes off; heater 100 volts negative with respect to cathode; grid, plate,

and metal shell connected to ground. At the end of this test tubes are tested for open heaters, heater-cathode shorts, and heater-cathode leakage current.

Intermittent Shorts:

This test is performed on a sample lot of tubes from each production run. Tubes are subjected to the Thyatron-Type Shorts Test described in MIL-E-ID, Amendment 2, Par. 4.7.7, except that tapping is done by hand with a soft rubber tapper*. The Acceptance Curve for this test is shown in Fig.3. In this test tubes are criticized for permanent or temporary shorts and open circuits.

Early-Hour-Stability Life Performance:

This test is performed on a sample lot of tubes from each production run to insure that tubes are properly stabilized. In this test tubes are operated for 20 hours at maximum rated plate dissipation. After 2 hours of operation and again after 20 hours of operation tubes are checked for transconductance under the conditions specified in CHARACTERISTICS RANGE VALUES for Transconductance (1). A tube is rejected if its transconductance after 2 or 20 hours of operation has changed more than 10 per cent from the 0-hour value.

100-Hour Life Performance:

This test is performed on a sample lot of tubes from each production run to insure a low percentage of early-hour inoperatives. Tubes are operated for 100 hours at maximum rated plate dissipation, and then subjected to the Intermittent Shorts test previously described. Following this, tubes must show a value not less than 6200 micromhos for Transconductance (1), and a value not greater than 0.2 microampere for Reverse Grid Current under the conditions specified in CHARACTERISTICS RANGE VALUES.

1000-Hour Conduction Life Performance:

This test is performed on a sample lot of tubes from each production run to insure high quality of the individual tube and guard against epidemic failures due to excessive changes in any of the characteristics indicated below. In this test tubes are operated for 1000 hours at maximum rated plate dissipation with a metal-shell temperature of 150° C and then criticized for inoperatives, reverse grid current, heater-cathode leakage current, and leakage resistance. In addition, the average change in transconductance of the lot from the 0-hour value for Transconductance (1) specified in CHARACTERISTICS RANGE VALUES, must not exceed 15 per cent at 500 hours, and 20 per cent at 1000 hours.

1000-Hour Standby Life Performance:

This test is performed on a sample lot of tubes from each production run. The tubes are operated for 1000 hours with only normal heater voltage applied. The tubes are then criticized for interelectrode leakage, reverse grid current, change in transconductance of individual tubes from the values at zero hours and cathode interface resistance greater than 25 ohms. Interface resistance is measured by Method B of ASTM specification F300-57T.

* Specifications for this tapper will be supplied on request.

OPERATING CONSIDERATIONS

The base pins of the 7895 fit the Cinch Mfg. Co. socket No. 133 65 10 001 or equivalent. The socket may be mounted to hold the tube in any position.

The *maximum ratings* in the tabulated data are established in accordance with the following definition of the *Absolute-Maximum Rating System* for rating electron devices.

Absolute-Maximum ratings are limiting values of operating and environmental conditions applicable to any electron device of a specified type as defined by its published data, and should not be exceeded under the worst probable conditions.

The device manufacturer chooses these values to provide acceptable serviceability of the device, taking no responsibility for equipment variations, environment variations, and the effects of changes in operating conditions due to variations in device characteristics.

The equipment manufacturer should design so that initially and throughout life no absolute-maximum value for the intended service is exceeded with any device under the worst probable operating conditions with respect to supply-voltage variation, equipment component variation, equipment control adjustment, load variation, signal variation, environmental conditions, and variations in device characteristics.

Information furnished by RCA is believed to be accurate and reliable. However, no responsibility is assumed by RCA for its use; nor for any infringements of patents or other rights of third parties which may result from its use. No license is granted by implication or otherwise under any patent or patent rights of RCA.

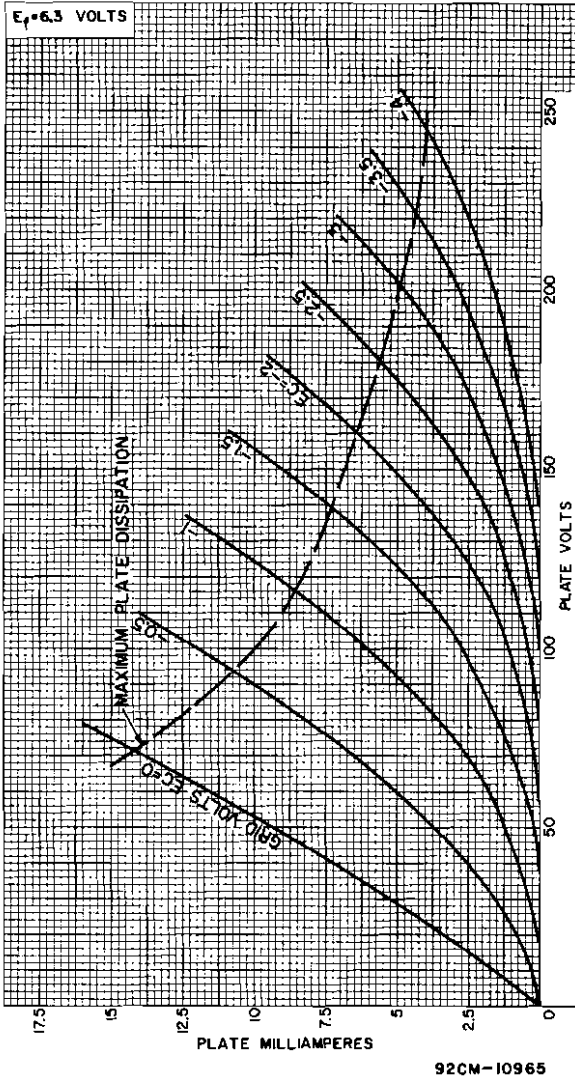

Fig. 1 - Average Plate Characteristics for Type 7895.

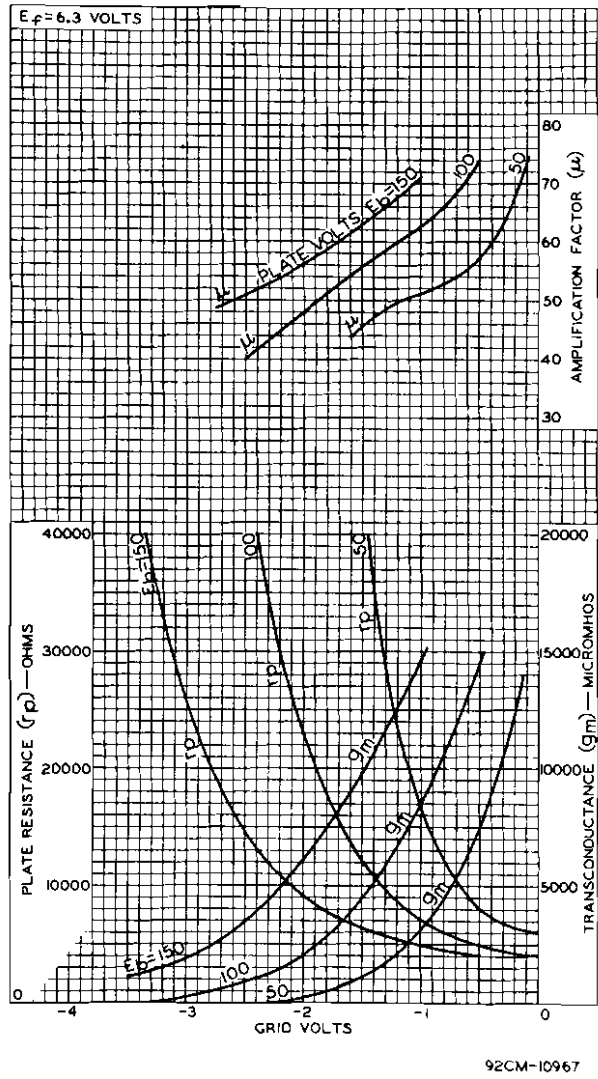

Fig. 2 - Average Characteristics for Type 7895.

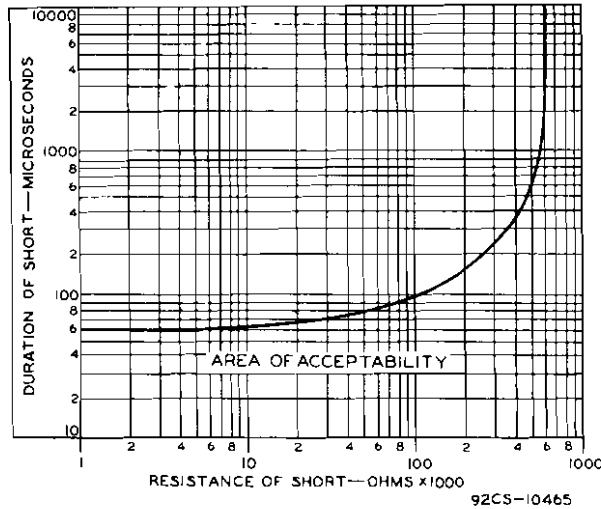
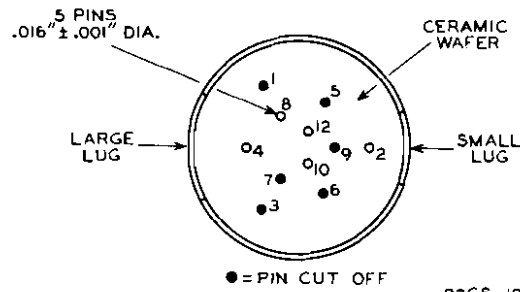
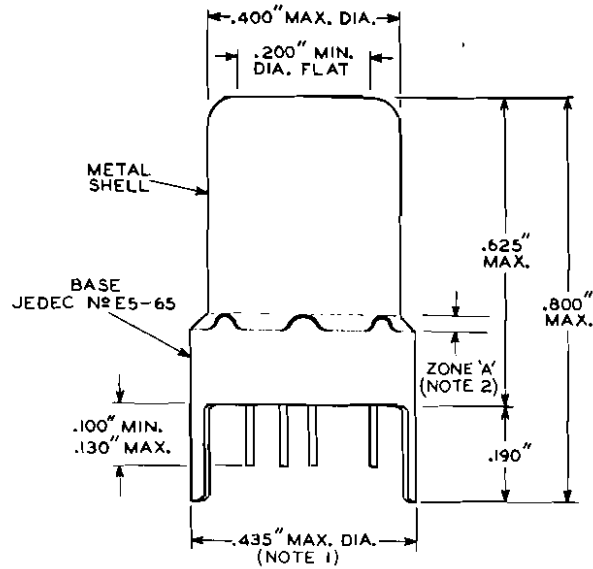

Fig. 3 - Thyatron-Type Shorts Test for Type 7895.

DIMENSIONAL OUTLINE



92CS-10970

NOTE 1: MAXIMUM O.D. OF 0.440" IS PERMITTED ALONG 0.190" LUG LENGTH.

NOTE 2: SHELL TEMPERATURE SHOULD BE MEASURED IN ZONE "A" BETWEEN BROKEN LINES.

BASING DIAGRAM (Bottom View)

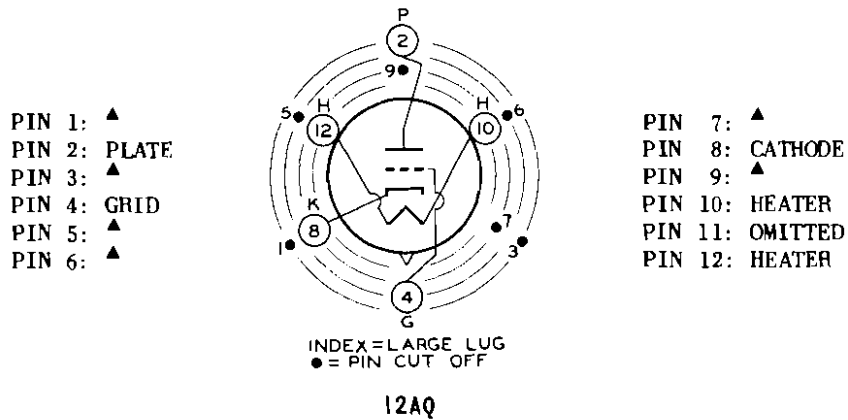

▲ Pin has internal connection and is cut off close to ceramic wafer--Do Not Use.

MEDIUM CERAMIC-WAFER TWELVAR BASE

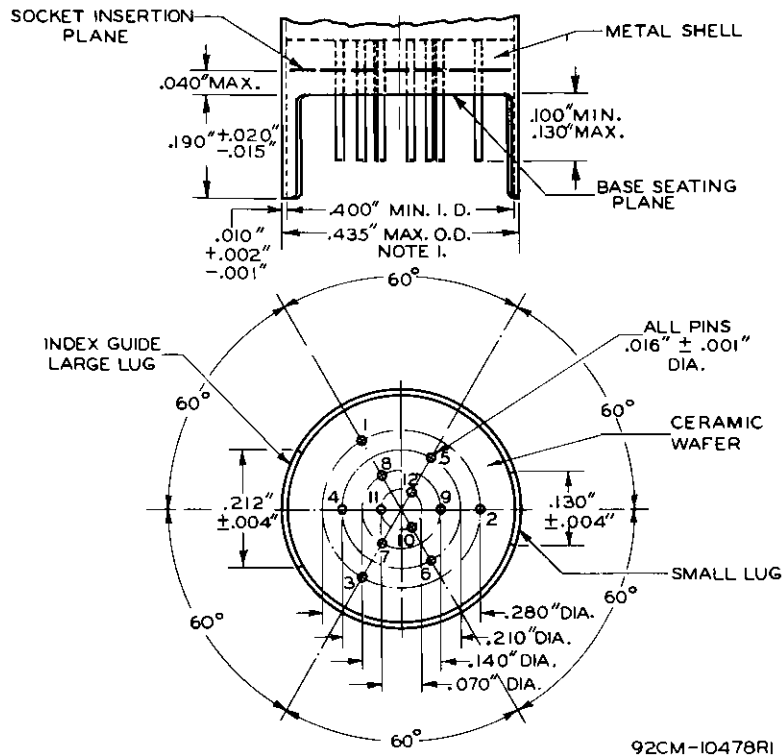

JEDEC No.	NAME	PINS
E12-64	12-Pin Base	1, 2, 3, 4, 5, 6, 7, 8, 9, 10, 11, 12
E5-65	5-Pin Base	2, 4, 8, 10, 12, (Note 2)

Note 1: Maximum O.D. of 0.440" is permitted along the 0.190" lug length.

Note 2: Pins 1, 3, 5, 6, 7, and 9 are cut off to a length such that their ends do not touch the socket insertion plane. Pin 11 is omitted.

PIN-ALIGNMENT GAUGE

Base-pin positions and lug positions shall be held to tolerances such that entire length of pins and lugs will without undue force pass into and disengage from flat-plate gauge having thickness of 0.25" and twelve holes of $0.0350" \pm 0.0005"$ diameter located on four concentric circles as follows: Three holes located on $0.2800" \pm 0.0005"$, three holes located on $0.2100" \pm 0.0005"$, three holes located on $0.1400" \pm 0.0005"$, three holes located on $0.0700" \pm 0.0005"$ diameter circles at specified angles with a tolerance of $\pm 0.08^\circ$ for each angle. In addition, gauge provides for two curved slots with chordal lengths of $0.2270" \pm 0.0005"$ and $0.1450" \pm 0.0005"$ located on $0.4200" \pm 0.0005"$ diameter circle concentric with pin circles at $180^\circ \pm 0.08^\circ$ and having a width of $0.0230" \pm 0.0005"$.

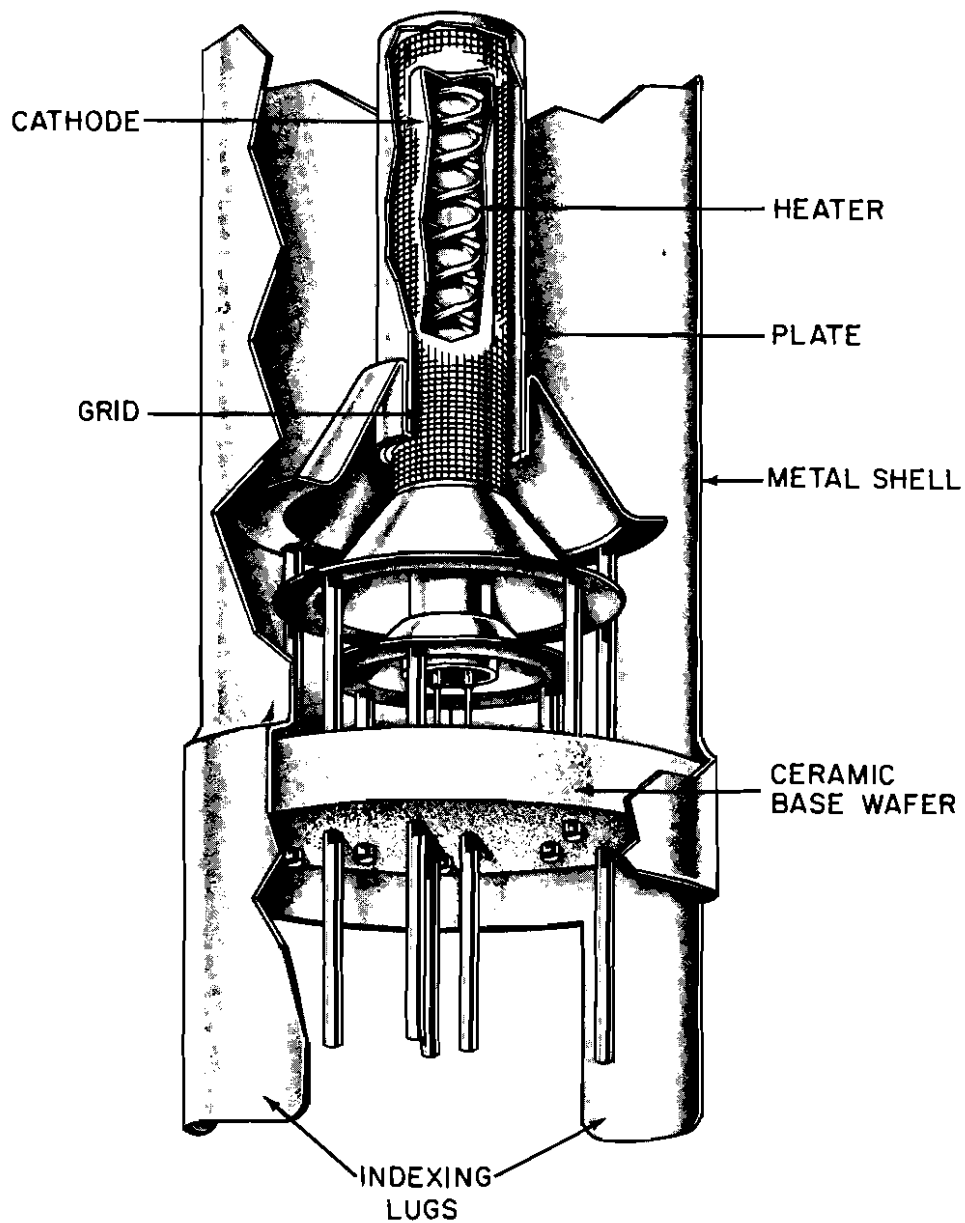

Fig.4 - Illustration of a nuvistor triode showing cylindrical electrodes and tripod-like supports.

